

Swingotilt®

ST15B

Machines 12 - 16 tonnes



Extreme flexibility and maximum safety. The grease lubricated Swingotilt® enables the excavator arm to make one endless rotation and tilt up to 40° in each direction. This means that the arm and bucket can bypass various obstacles, release loads easier and reduce the need for manual assistance with maneuvers. Swingotilt® increases safety for both the driver and those around the excavator.

Swingotilt® ST15B is supplied complete with hydraulic hoses, hydraulic connections, wiring and installation manual.

ST15B can be adapted for most machines in the size range. It is available with most types of quick coupler systems, and with a direct mounted upper/lower section.



Available with double-acting cylinder or telescopic cylinder.

TECHNICAL SPECIFICATION SWINGOTILT® ST15B

Infinite rotation 360°
Tilting 2 x 40°
12/24VDC
Grease lubricated

Valve system
System Pro
System P
System TXSC
System TXC
System TS

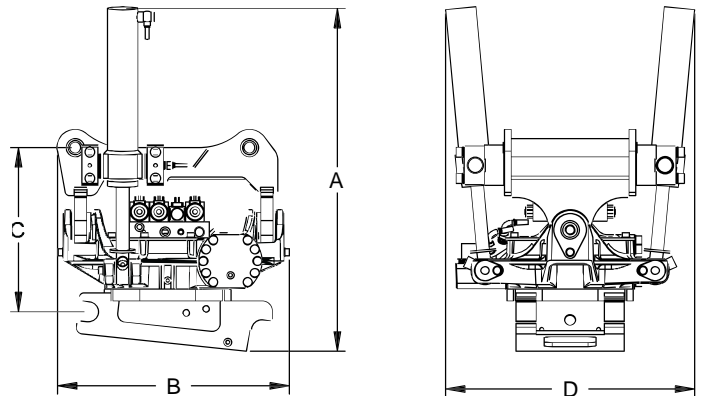

Mounting	S60	SMP2
Approx weight (kg)	390	400
Dimensions A / B / C / D	934 / 726 / 489 / 706	1002 / 807 / 560 / 789
Tilt angle	2 x 40°	
Rotation	Infinite 360°	
Oil flow Min / Max	40 / 80 L/min	
Operating pressure Min / Max	18 / 35 MPa	
Tilt torque at 21 Mpa	52,2 kNm	
Rotation speed	7 sec / rotation	
Torque	7000 Nm	

Weights can vary depending on design of product